

# Models 370 & 470



Setra Models 370 and 470 offer extremely high accuracy and unmatched stability in a digital output configuration. Environmental monitoring and test & measurement systems around the world rely on Setra's experience in barometric pressure measurement instrumentation, as well as high accuracy measurements of higher pressures. Both models utilize Setra's unique SETRACERAM™ sensor, which is combined with advanced microprocessor based circuitry and sophisticated firmware to provide system accuracy to better than  $\pm 0.02\%$  full scale.

The Model 370 Digital Pressure Gauge is an extremely versatile instrument. Pressure and altitude data is displayed on a 6 digit LCD and is also accessible through a bidirectional RS-232 port. A numeric key pad is provided for easy access to engineering unit conversions, min/max tracking, entry of Hi/Lo alarm setpoints, nonlinear functions and calibration procedures. The 370 is also available with an optional rechargeable battery pack to bring lab accuracy to the field.

The Model 470 is functionally the same as the 370. It is intended for applications which do not require local display of pressure or key pad access to commands. The 470's solid stability, reliability and versatility make it the first choice for weather observation systems worldwide. Both units are programmable for continuous, interval or on-demand printing at an adjustable (300-9600) baud rate.

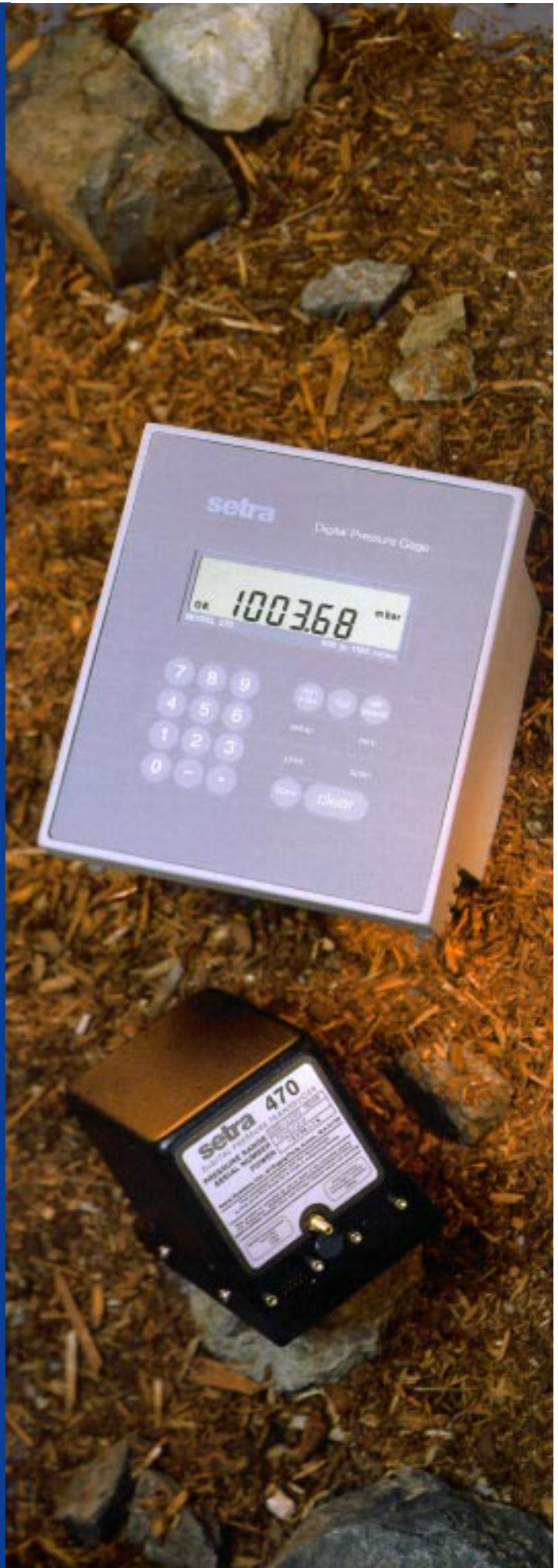

U.S. Patent No. 4168518



# Models 370 and 470 Specifications

## Pressure Ranges

Type of Pressure	Pressure Range	Readout or Report	Altitude Range <sup>1</sup>
Barometric	600 to 1100 hPa/mb	600.00 to 1100.00	-1000 to 13,800 ft.
	800 to 1100 hPa/mb	800.00 to 1100.00	-1000 to 6,400 ft.
Absolute	0 to 10 psia	10.0000	10,300 to 100,000 ft.
	0 to 20 psia	20.0000	-1000 to 100,000 ft.
	0 to 50 psia	50.0000	-1000 to 100,000 ft.
	0 to 100 psia	100.0000	-1000 to 100,000 ft.

Proof Pressure: 150% of full scale pressure range

Pressure Media: Clean dry air or other gases (non-condensable)

## Performance Data

Accuracy <sup>2</sup>	± 0.02% FS <sup>3</sup> at 70°F (21°C)
Non-Linearity	± 0.012% FS (End Point)
Hysteresis	0.010% FS
Non-Repeatability	0.010% FS
<b>Thermal Effects<sup>4</sup></b>	
Compensated Range °F (°C)	+32 to +110 (0 to +45)
Zero Shift %FS/100°F (°C)	0.002 (0.004)
Span Shift %FS/100°F (°C)	0.001 (0.002)
Altitude Resolution	1 ft. (4 ft. for 100 psi range)
Stability	0.005% FS, 24 hours
	0.02% FS, 30 days
	0.05% FS, 1 year

**Notes:** 1. Altitude is calculated using a polynomial expression, which is derived from the standard atmosphere curve, and corrected to sea level by the methods outlined in "Smithsonian Meteorological Tables, Vol. 114". Ranges greater than 20 psia not recommended for altimeter certification.

2. RSS of Non-Linearity, Non-Repeatability and Hysteresis.

3. FS = 300 hPa/mb for 800-1100 hPa/mb range; 500 hPa/mb for 600-1100 hPa/mb range.

4. Unit calibrated at 70°F. Maximum thermal error is computed from this datum.

## Output Data

### Model 370

#### Display

6 digit Liquid Crystal Display (LCD) with annunciators for pressure/altitude engineering units (**PSI, mbar, hPa, mmHg, in.Hg, mmH<sub>2</sub>O, in.H<sub>2</sub>O, ft, m, units**), **HI/LO ALARM**, pressure signal stability (**O.K.**) and barometric pressure corrected to sea level (**SEA LEVEL**).

#### Digital Output

Bidirectional RS-232 interface. All display data can be transmitted on the interface (Model 370) and all keyboard functions and commands can be duplicated using a remote terminal or keyboard.

### Model 470

#### Digital Output

Pressure data for the Model 470 is accessible through the Bidirectional RS-232 I/O port, which is user programmable for continuous, interval or on-demand printing at an adjustable (300-9600) baud rate. The data is reported in a simple string of ASCII characters in response to a command consisting of an ASCII character, for example, P (for PRINT) instructs the device to report a pressure reading.

The same functions are available on the Model 470 as shown in the 370 photo above.

## Operating Power

Model 370 110/220 VAC (-10% to +20%), 50/60 Hz., optional 12 VDC internal rechargeable battery pack (approx. 8 hours between charges). Approximately 4 watts power consumption.

Model 470 5 VDC ±1%, 70 mA max.



## Applications

- Automatic Weather Reporting Systems
- Pressure Transfer Standard
- Altimeter Calibration Recertification
- Lab or Production Process Monitoring
- Altitude Chambers

## Features

- ± 0.02% Full Scale Accuracy
- High Resolution 6 Digit LCD Display for Pressure or Altitude Monitoring (M370)
- Bidirectional RS-232 Digital Communications I/O Port
- Engineering Unit Conversions for Pressure and Altitude
- Digital Altimeter Setting Indicator (DASI) and Corrected Altimeter Mode
- Programmable Non-Linear Functions

*When it comes to a product to rely on - choose the Model 370/470. When it comes to a company to trust - choose Setra - an ESOP (Employee Owned) Company.*

**TEESING**

**setra**

**800-257-3872**

*Specifications are subject to change without notice.*

## Digital Interface

Bidirectional RS-232 interface. Access data, functions and commands via an RS-232 compatible remote terminal, data acquisition system or data storage device. 300, 600, 1200, 2400, 4800, 9600 Baud Rate, adjustable. Typical data printouts are listed on the right:

System Status		Datalogging	
Elev:	+ 120 feet		
Max:	+ 15.552 PSI A		600. sec/reading
Min:	+ 11.793 PSI A		14.595 PSI A
Hi A:	+ 16.000 PSI A		14.596 PSI A
Lo A:	+ 11.000 PSI A		14.598 PSI A

## Model 370 Physical Description

Pressure Fitting	1/8" - 27 NPT Internal
Power Cord	5 Foot Length, 3-Prong
Weight	12 lbs. (with Battery Pack)

## Available Options

624	Installed Rechargeable Battery Pack
864	19 inch Rack Mount Kit

## Outline Drawings

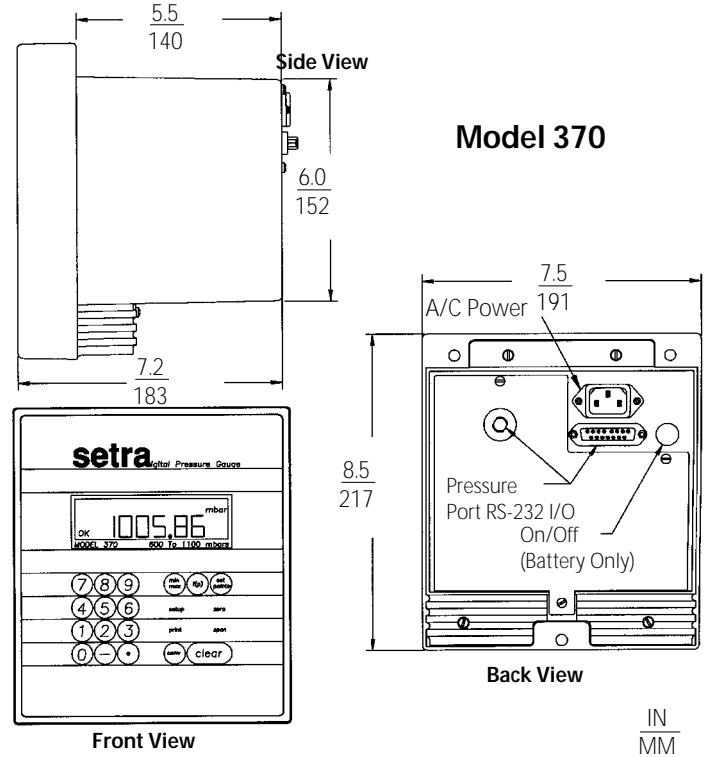

## Model 470 Physical Description

Pressure Fitting	Barbed Fitting for 1/8" I.D. Tubing
Pressure Connection	10-32 Internal Thread
<u>Electrical Connections</u>	
Excitation	DB-9S, (9 Pin D-Subminiature Female): Pin: 3 GRD, 9 + 5 VDC
Communications	DB-9S, (9 Pin D-Subminiature Male): Pin: 2 TXD, 3 RXD, 5GRD
Weight	Approximately 2.4 lbs

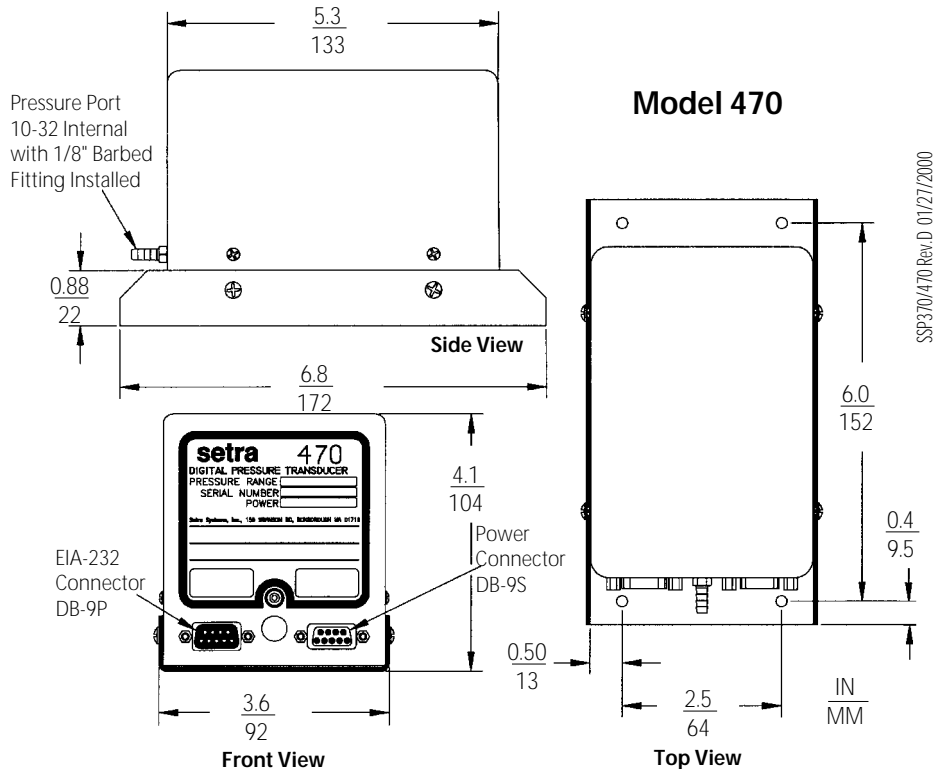

## Ordering Information

Order as Model 370 digital pressure gauge.  
Specify pressure range and options.

Order as Model 470 pressure transducer.  
Specify pressure range and options.

Note: Setra quality standards are based on ANSI-Z540-1.  
The calibration of this product is NIST traceable.

While we provide application assistance on all Setra products, both personally and through our literature, it is the customer's responsibility to determine the suitability of the product in the application.

